

Dewpoint Transmitter Series XDT



-148°F to + 68°F Dewpoint



COSA dewpoint transmitters are used wherever the dewpoint in a gas is critical

APPLICATIONS INCLUDE:

- Monitoring and control of air dryers
- Plastic dryers
- Welding and laser gases
- Petrochemical feedstock gases
- Natural gas
- Clean rooms
- Transformer and switch gear insulation gases
- Glove boxes
- Cryogenic gases
- Heat treating furnaces
- Industrial specialty gases
- Many more



Class I Division 1 Groups A,B,C, & D;
Class II Groups E, F, & G



Manufactured with pride
in the USA

Features Xentaur HTF™ Al₂O₃ Technology

visit www.cosa-instrument.com for

Process Analyzers: Moisture in Gases (Portable, Loop-powered, HART Protocol, Relative Humidity)
Moisture in Liquids: H₂ Analyzers, O₂ Analyzers, Gas Chromatographs, Calorimeters and Other Speciality Instrumentation

GENERAL

The COSA digital dewpoint transmitters are designed as compact, simple and reliable instruments, which will continually monitor air dryer performance, compressed air quality and dry gas moisture, from ambient dewpoint levels to as low as -148°F (-100°C).

APPLICATIONS

COSA dewpoint transmitters are used wherever the dewpoint in a gas is critical. Applications include: monitoring and control of air dryers, plastic dryers, welding and laser gases, petrochemical feedstock gases, natural gas, clean rooms, glove boxes, transformer and switch gear insulation gases, cryogenic gases, heat treating furnaces, industrial specialty gases and many more.

ELECTRONICS

The transmitter electronics take full advantage of state of the art microprocessor technology and offer many advanced intelligent features. With optional dual alarms, analog and digital outputs, the COSA dewpoint transmitters can be used as indicators, alarm units or controllers.

PROGRAMMABLE ALARM RELAYS OPTION

The two optional alarm relays can be independently programmed to switch at any dewpoint with variable hysteresis, which makes the transmitter ideally suited as an energy saving controller for desiccant dryers in “dewpoint demand” mode or safety cutoff in process control, high power laser, etc. The status of the relays is shown on the display with flashing HI or LO indicators while displaying the dewpoint.

ANALOG AND DIGITAL OUTPUTS OPTIONS

Analog and digital outputs are isolated from the sensor. The analog current or voltage output can be programmed to span the full or a portion of the range and is linear to the selected engineering units. The RS-232 interfaces into the serial port of any PC or Mac, for a simple operation with any standard communications program.

USER-FRIENDLY INTERFACE

The instrument is operated through a menu driven user interface consisting of a custom LCD display with backlight, and four push buttons.

ENGINEERING UNITS

The user can select from the following engineering units. Dewpoint in °C or °F, ppmv, g H₂O/m³, lbs H₂O/ million scf.

PRESSURE CORRECT FUNCTION

Results are displayed at sensor pressure or by pushing the Pressure Correct key at a user selectable alternate pressure, such as the line pressure.

SPANCHECK IN THE FIELD

This field calibration procedure is fully automated and the user is prompted through a simple one minute procedure, which requires no additional equipment.

ERROR INDICATION

The instrument has indication for sensor open, short or electronic system failure, which can activate any of the alarm relays.

NIST / NPL TRACEABILITY OPTION

Certificates for NIST and NPL traceability are available upon request. Instruments can be recertified periodically at COSA's laboratories.

SAME TRANSMITTER - MULTIPLE CONFIGURATIONS



Model XDT-OEM is a stand alone board suitable for mounting in existing enclosures. Connections are made through a pluggable screw terminal block which allows cables to leave the board vertically or horizontally.

The electronic board can be broken into two parts and sandwiched to accommodate space constraints.



Model XDT-PM houses the transmitter in a panel mount industry standard DIN 43700 box, 3" (7.5cm) deep. Connections are made through a pluggable screw terminal block.

The panel mount model is available with the push buttons on the outside of the front panel (shown above) or with the push buttons hidden behind the front panel.



Model XDT-NEMA houses the transmitter in a NEMA 4 (IP65) enclosure. Ideally suited for industrial environments.

Can be ordered UL approved for use in Hazardous Locations Class I Division 2 Groups A, B, C & D; Class II Groups F & G. And optionally Providing Intrinsically Safe output for use in Hazardous Locations Class I Division 1 Groups A, B, C, & D; Class II Groups E, F & G.

Also Available: XDT in explosion proof enclosure, UL approved for use in Hazardous Locations Class I Division 1 Groups B, C & D; Class II Groups E, F & G. Provides Intrinsically Safe output for use in Hazardous Locations Class I Division 1 Groups A, B, C & D; Class II Groups E, F & G

The Xentaur HTF™ Aluminum Oxide sensor is the product of years of intensive research and has been thoroughly field proven. Xentaur HTF™ technology offers significant performance advantages over all other aluminum oxide moisture sensors.

HIGH CAPACITANCE RESPONSE

Due to a hyper-thin film and a special activation process, Xentaur sensors have a capacitance change over their full range, several orders of magnitude larger than that of conventional aluminum oxide sensors. Additionally,

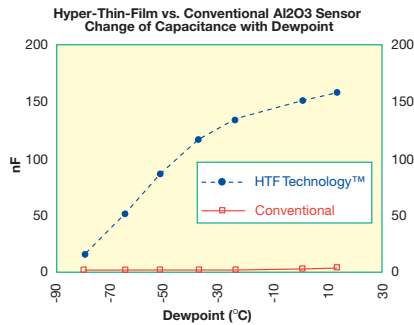

this change is quasi linear and its sensitivity to temperature is negligible. The advantages of a linear high capacitance response are: better sensitivity, better repeatability and

faster response times. Also, the measurement system is less prone to noise and drift, and signal conditioning is kept to a minimum.

INTERCHANGEABLE SENSORS

HTF™ Al₂O₃ high capacitance sensors are manufactured with high uniformity. Consequently, sensors are freely interchangeable without factory calibration or changing of EPROMS, as is required with conventional aluminum oxide sensors.

SPANCHECK WITHOUT REFERENCE STANDARDS

Xentaur HTF™ high capacitance sensors have a very low residual capacitance when dry, and saturate at a predesigned level of humidity above +68°F (+20°C). This allows a span check of the sensor by cupping the sensor in the palm of one's hand for one minute, and adjusting the instrument to its upper range limit. The advantages of this span check system are obvious: Xentaur sensors can be field calibrated anywhere, anytime without using expensive and cumbersome calibration standards. Sensors do not have to be returned to the factory for recalibration, which also eliminates the need for a second stand-by sensor.

WATERPROOF SENSORS

Xentaur HTF™ sensors are available in waterproof versions. Waterproof sensors can be fully immersed in water and will go back into operation after drying down.

HTF™ Al₂O₃ ADVANTAGES:

- Up to 600x more sensitive than conventional sensors
- Sensors are freely interchangeable
- Field calibration without reference standards
- Faster response
- Better repeatability
- Longer sensor life
- Less drift
- Negligible temperature coefficient

ADVANCED MECHANICAL SENSOR DESIGN

Xentaur HTF™ sensors have been designed for the requirements of tough industrial environments. The sensor element is encapsulated in a 100 micron stainless steel sintered filter. The filter housing is screwed onto a stainless steel sensor fitting which is available for pressures of up to 5000 PSI (FM tested).



When sensor elements have to be replaced the sensor fitting can be saved. The sensor fitting has two mounting threads, which make it easy to use existing sample cells. The cable is connected through a BNC connector.

TECHNICAL SPECIFICATIONS OF XENTAUR HTF™ SENSORS

SENSOR ELEMENT:

Type: Hyper Thin Film high capacitance Al₂O₃
 Dewpoint range:
 XTR-100 -148°F to +68°F (-100°C to +20°C)
 XTR-65 -85°F to +68°F (-65°C to +20°C)
 Capacitance: 15 nF to 200 nF
 Accuracy: ±5.5°F (± 3°C)
 Repeatability: ±0.9°F (±0.5°C)
 Response time*: For a step change from -40°C to -60°C:
 63% in 90 seconds
 90% in 450 seconds
 Temperature range: -22°F to 104°F (-30°C to +50°C)
 Sample Flow range
 (linear velocity at 1 atm): Static to 100 m/s
 Storage temperature: -40°F to +120°F (-40°C to 50°C)
 SpanCheck: Sensor saturates at dewpoint above +68°F (+20°C)

FITTING:

Pressure operating range: Standard: 500 PSI (34 bar)
 Optional: 5000 PSI (340 bar)
 Mechanical connections: 14mm x 1.25 mm threads, and
 3/4"-16 threads (other threads available)
 Electrical connections: Female BNC connector
 Sensor cable: Coaxial cable (75Ω with maximum capacitance of 50 pF/m).
 Maximum cable length: 3,000 ft.



* These response times are not directly comparable to competitors data because of differences in measurement methodology and data presentation. Please inquire for detailed comparisons between Xentaur and other major sensor manufacturers. Our sensors are significantly faster.

For more details:
<http://www.xentaur.com>

XDT SERIES TECHNICAL SPECIFICATIONS

Transmitter:

- Sensor type: High capacitance Al₂O₃
- Input Resolution: 0.1°C dewpoint
- Indicators: LCD with backlight, 3.5 digits and custom legends for units and mode, audio alert
- Engineering units: Dewpoint in °F and °C, ppmv, g H₂O/m³, lbs H₂O/mm scf,
- Controls: 4 push buttons, all settings stored in EEPROM
- Output options: 4-20mA, 0-24mA or voltage outputs, linear to selected engineering units, programmable span and range, 0.1°C dewpoint resolution.
- RS-232 , baud rate 9600, resolution 0.1°C dewpoint
- Isolation: Sensor is isolated from the power supply, analog output and RS-232.
- Alarm relays option: Two programmable alarm relays with programmable variable hysteresis, rated at 10A @240V. Failure indication programmable to trigger alarm relays.
- Power requirements: 100 - 240 VAC, 50 or 60 Hz, autoranging or by order 12VDC or 15-30VDC 0.5A
- Connections: Pluggable screw terminal block
- Enclosure: Polycarbonate, Nema 4/4x Dimensions 4.7" x 6.3" x 3.5" (w x h x d); DIN 43700 - 3" deep.
- Temperature range of electronics: 14° to 122°F (-10° to 50°C)
- Optional Features: a) Medical Breathing Air Monitoring and Alarm Option, complies with the recommendations of NFPA 99, 1996 edition
 b) On-board battery backed real-time clock option, facilitating Scheduled Timer Activated Single Point Self Calibration/Verification procedure for sample systems equipped with an electrically actuated switchover valve.
- Warranty: 1 year for full workmanship and defective parts.



Class I, Division 1 Groups A, B, C, & D; Class II Groups E, F, & G;
 Class I Division 2 Groups A, B, C, & D; Class II Groups F & G; EEx d[ia] IIB+H2

Dimensions of Element and Fitting (other threads are available)

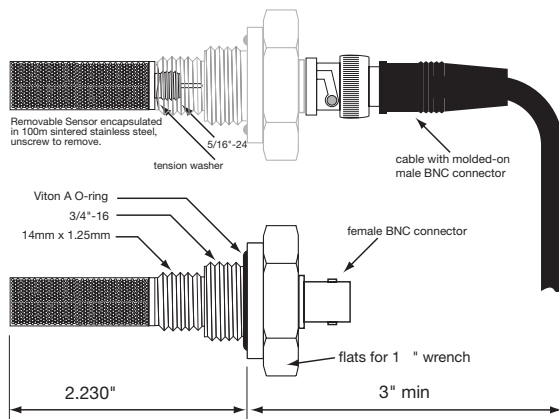

Sample cells and complete sampling systems available. For more information, refer to website

Dimensions XDT-OEM

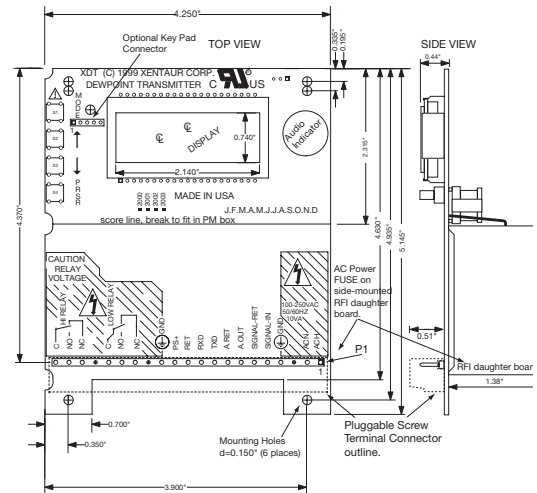

Dimensions XDT-NEMA

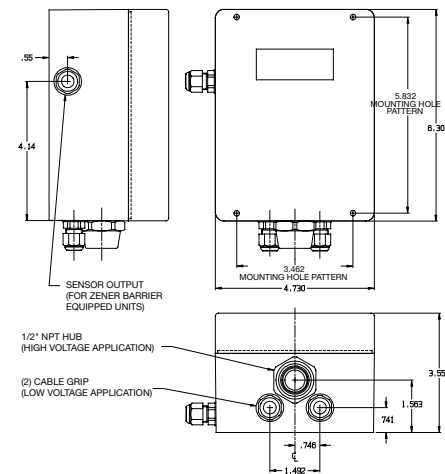

Dimensions XDT-PM

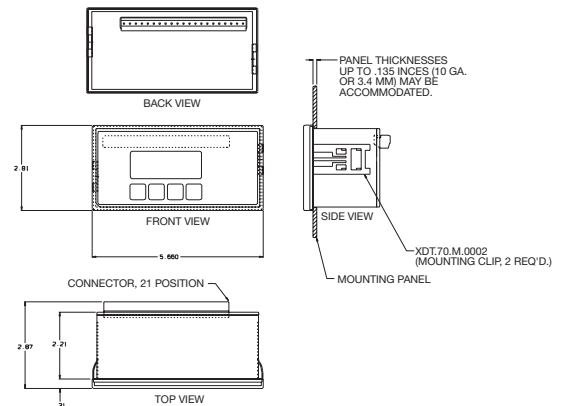

COSA INSTRUMENT CORPORATION

Texas Office: 7125 North Loop East, Houston, TX 77028
 Tel: 713-947-9591, Fax: 713-947-7549

New Jersey Office: 55 Oak Street, Norwood, NJ 07648
 Tel: 201-767-6600, Fax: 201-767-6804

email: cosa@cosaic.com
www.cosa-instrument.com

REPRESENTED BY: